

# PHYSICAL SCIENCE

## MR. SHEPHERD

### MOUSETRAP CAR PROJECT

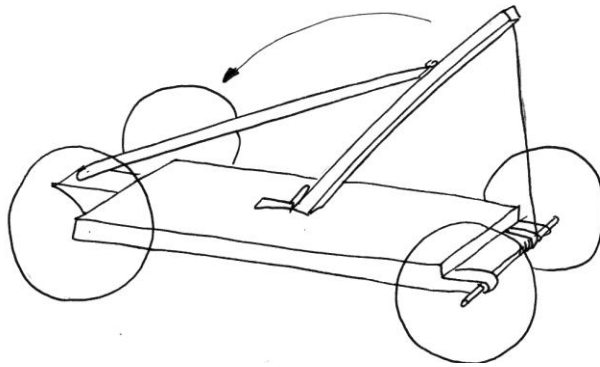

**Introduction:** You will build an originally designed vehicle powered solely by the energy of one standard-sized mousetrap.

A very popular method of propulsion is to tie one end of a string to the arm (or an extended lever arm) on the mousetrap and the other end to the axle. By winding the string around the axle, the mousetrap's spring, when released, pulls on the string causing the wheels to turn and thus making the car move (there are, however, other creative ways to convey power from the mousetrap to the car).

**Objectives:** The objective of this project is to...

- a) Design a mousetrap car that will travel a maximum speed/acceleration over a 5 meter race.
- b) Demonstrate an understanding of the physics principles incorporated in your design (in a report).

The project consists of 5 phases:

- Mousetrap Car Design
- Procurement of parts - Pass CHECKPOINT 1
- Mousetrap Car Construction - Pass CHECKPOINT 2
- Mousetrap Car Performance Evaluation - Race day.

- Mousetrap Car Physics Analysis (Report)

### Design Instructions:

1. The vehicle must be powered by a single "Victor" brand mousetrap or equivalent (no rat traps allowed). You are not allowed to "heat treat" the spring to enhance tensile strength.

2. You have complete design freedom concerning vehicle size, vehicle weight, and materials used (except for the mouse trap "engine"). However use common sense, nothing sharp or dangerous may be used on the car.

**3. CAR-KITS PURCHASED AT A HOBBY STORE OR ON-LINE ARE ABSOLUTELY PROHIBITED.** The intent of this project is for you to research, design, and build your own car from "scratch" i.e. from individual components you have purchased, already have on hand at home or made. Please be aware that I am confident in my ability to identify purchased kits. Parts from toys (Example: tires from models, K'NEX parts, Erector Set parts, etc) are allowed if prior approved either before or at checkpoint 1.

4. You will not be permitted to "push start" your vehicle i.e. upon release, your vehicle must start moving on its own.

5. Only the preset race distance will be measured; "total distance traveled" does not count (i.e. the straighter the travel line, the better your grade will be as your race time will be faster).

6. Displacement will be measured from the starting line position to the front-most part of the vehicle at its final resting point.

7. Your goal is 5 meters or more. All cars entered must achieve a minimum of 3 meters displacement to pass the performance part of the grade. Please examine the grading rubric (see link below); *car performance is a major part of your project grade so test your design, make improvements and then test some more!*

# The Mousetrap Car Physics Analysis Report

Answer the following questions completely (include formulas and/or calculations where appropriate). Your answers may be written or typed and a minimum of 300 words.

1. What are the two types of friction that affect the performance of your vehicle?
2. What problems related to friction did you encounter and how did you solve them?
3. What factors did you take into account to decide the number of wheels you chose in your design?
4. What kind of wheels did you use in each axle? What is the effect of using large or small wheels?
5. Explain how Newton's first, second and third laws apply to the performance of your vehicle.
6. Discuss the effect of the length of the lever arm in the pulling force of your vehicle.
7. How is the balance of a wheel, around its center, related to the vehicle's performance?
8. How does the distribution of weight of the vehicle affect the traction of the wheels?
9. Discuss the major problems encountered in the performance of your vehicle and what did you do to solve them.

# Mouse Trap Car Project RUBRIC

Date \_\_\_\_\_ Car Name \_\_\_\_\_

Student \_\_\_\_\_ Class \_\_\_\_\_

## I. MOUSETRAP CAR CONSTRUCTION AND DESIGN (15 pts possible)

**15 points:** Excellent application of design, construction and assembly.

**13 points:** Very good construction and assembly and very good attention to detail.

**10 points:** Good construction and assembly and some attention to detail.

**8 points:** Fair construction and assembly. Minimal attention to detail.

**3 point:** Last minute project. No attention to detail.

**0 points:** Car is not homemade i.e. purchased kit was used: car is disqualified from race.

## II. 2 CHECKPOINTS (20 points, 10 pts possible per checkpoint)

**10 points:** All required checkpoint work completed.

**0-3 points:** Less than all work accomplished at checkpoint.

## III. Race-Day worksheet (15 pts possible per checkpoint)

**15 points:** Completed by the beginning of class the day after Race-Day.

**0 points:** Incomplete worksheet the day following Race-Day.

## IV. MOUSETRAP CAR PERFORMANCE (25 pts possible)

### Speed Class

**25 points:** Final displacement is 5 m or greater

**15 points:** Final displacement is 3-5 m

**0 points:** Final displacement is less than 3 m

## V. MOUSETRAP CAR PHYSICS ANALYSIS REPORT (25 pts possible)

**20-25 points:** Demonstrates excellent conceptual understanding of the physics principles behind a mousetrap car. Applies this understanding in conducting an excellent, meaningful investigation.

**15-20 points:** Demonstrates good conceptual understanding of the physics principles behind a mousetrap car. Applies this understanding in conducting a good investigation.

**12-14 points:** Demonstrates minimal understanding of physics principles behind a mousetrap car. Conducts a basic investigation.

**0-11 points:** Demonstrates poor conceptual understanding of the physics principles behind a mousetrap car. Does not fully apply this understanding in conducting a meaningful investigation.

**100 Point rubric scale.**

**Your Final Grade that will be in the grade book is your total points from the rubric multiplied by four.**

**400 Total Points Possible!!!**

### **AWARDS:**

Award recognition will be given for greatest displacement, greatest speed, greatest acceleration, best engineered vehicle, and most artistic design.

## **Checkpoint #1**

1<sup>st</sup> Period: \_\_\_\_\_ 3<sup>rd</sup>, 4<sup>th</sup>, 6<sup>th</sup>, 7<sup>th</sup>, 8<sup>th</sup> Periods: \_\_\_\_\_

You must have completed your finalized design and gathered/purchased all component parts and materials for assembly. You must bring in all component car parts to school for approval.... be prepared to answer any construction questions presented to you (after examining your materials, I might ask questions that pertain to your car design... make sure you can explain what you are going to do with all the parts and construction materials and how your design works). Some car construction may have begun at this point.

## **Checkpoint #2**

1<sup>st</sup> Period: \_\_\_\_\_ 3<sup>rd</sup>, 4<sup>th</sup>, 6<sup>th</sup>, 7<sup>th</sup>, 8<sup>th</sup> Periods: \_\_\_\_\_

You must provide proof of construction progress on your project... you will bring to class either your partially finished car or your finished car for approval. Finished cars can be tested and modified if necessary for performance improvement. Modifications can be made as often as desired up to the day the project is due.

## **Mousetrap Car Lab Schedule:**

3<sup>rd</sup>, 4<sup>th</sup>, 6<sup>th</sup>, 7<sup>th</sup>, 8<sup>th</sup> Periods

- \_\_\_\_\_: Introduction to Mousetrap Lab and presentation of project.  
Homework: Procure parts and work on design.
- \_\_\_\_\_: *Checkpoint #1*- Design must be finalized and presented to Mr. Shepherd
- \_\_\_\_\_: *Checkpoint #2*- Cars must be at least 50% built or finished. If car is not complete it must be taken home to complete for Homework!!!
- \_\_\_\_\_: Race Day! Students must complete race-day worksheet during Race Day. Race-Day worksheet and Physics analysis report are due \_\_\_\_\_.

## Mousetrap Car building basics

A mousetrap powered car is a vehicle that is powered by the energy of a wound-up mouse trap's spring. The most basic design is to tie one end of a string to the tip of a mousetrap's snapper arm and then the other end of the string has a loop that is designed to "catch" a hook that is glued to a drive axle. Once the loop is placed over the axle hook, the string is wound around the drive axle by turning the wheels in the opposite direction to the vehicle intended motion. As the string is wound around the axle by the turning of the wheels, the snapper's lever arm is pulled closer to the drive axle causing the mousetrap's spring to "wind-up" and store energy. When the drive wheels are released, the string is pulled off the drive axle by the mousetrap causing the wheels to rotate.

### **Step #1:**

A string is attached to the mouse trap's lever arm and then hooked to the drive axle. The string has a loop knot tied at one end that is designed to "catch" a hook attached to the drive axle. The string's loop knot is designed so that the string can release itself after the pulling force is spent. If the axle's hook is too long or the string's loop knot is too tight, the string will not properly release from the axle causing the vehicle to suddenly stop.

### **Step #2:**

To wind the string around the axle, the wheels are turned in the direction opposite to the motion of the vehicle's travel. It is important that the string NOT be wound loosely or it will snag itself as it is pulled from the axle by the lever arm, the string should carefully be wound tight and uniform around the axle. Do not push on the mousetrap's lever arm during this process; you want the string to be tight and to pull the lever arm over.

### **Step #3:**

Once the car is released, the string is pulled off the axle causes the wheels to rotate propelling the vehicle. If the mousetrap is located too close to the drive axle the wheels can spin at the start wasting energy.

## How to Build a "Speed" Mousetrap Car

When you build a vehicle for speed, you want to release the mousetrap's energy very quickly or at a high power output. This way your vehicle can get to top speed as soon as possible. You can change the power output of your vehicle by changing one or all of the following: where the string attaches to the mouse-trap's lever arm, the drive wheel diameter, or the drive axle diameter. The amount of energy released by using a short lever arm or a long lever arm is the same, but the length of the lever arm will determine the rate at which the energy is released and this is called the power output. Long lever arms decrease the pulling force but increase the pulling distance, thereby decreasing the power output. Short lever arms increase the pulling force over a shorter pulling distance thereby increasing the power output. If you are building a mouse-trap car for speed, you will want the maximum power output, just before the wheels begin to spin-out on the floor. Maximum power output means a higher rate of energy being transferred into motion or greater acceleration of the vehicle.

Greater acceleration can be achieved by:

- increasing the power torque
- using a short length lever arm
- having a small axle to large wheel ratio.
- build a light-weight vehicle.
- wheels should have low rotational inertia.

If you are building a distance vehicle, you want to minimize the power output or transfer stored energy into energy of motion at a slow rate. This usually means having a long lever arm and a large axle-to-wheel ratio. If you make the lever arm too long, you may not have enough torque through the entire pulling distance to keep the vehicle moving, in which case you will have to attach the string to a lower point or change the axle-to wheel ratio. Pictures of "Speed" class cars.

## Mr. Shepherd's words of wisdom:

I can assure your grade is directly proportional to the time you spend on this project. It is extremely difficult to earn a "C" or better without adequate research, design, testing and redesign. Too many students in the past have created an initial design that didn't work well and didn't redesign or make the proper adjustments due to lack of work ethic. A large portion of your grade depends on your car's performance; make sure your car will perform when the time comes. That means design it, build it, test it, re-design, re-test it and repeat this process as many times as necessary to achieve your goals.... This is your one quarterly project that you are working on at home. I have given you ample time to accomplish your project goals... don't procrastinate if you want a good grade!